

# Plug-type End Deactivators

## End Deactivation Using Plug-type Unloaders

Deactivation of a cylinder end should be considered when large changes in either load or flow are required. When paired with clearance volume pockets, a significant amount of relatively smooth unloading can be achieved.

When the plug is closed, gas travels through the suction valves as normal. When the plug is raised (opened), the suction valve port is always open and thus no gas is compressed — when the piston tries to compress the gas, it just pushes the gas back up through the hole exposed in the suction valve.

Finger-type unloaders have small, breakable fingers pushing on the valve plates: plug-type unloaders put no direct force onto the valve plates. This major difference results in less maintenance issues in a critical component area — compressor valves.

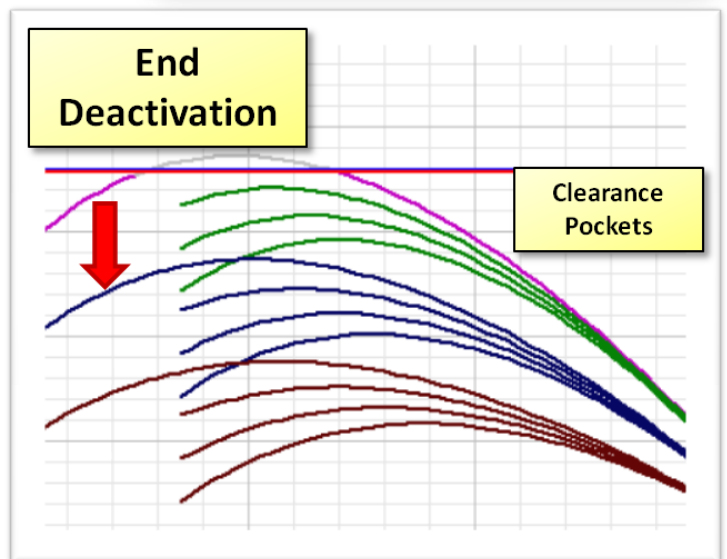
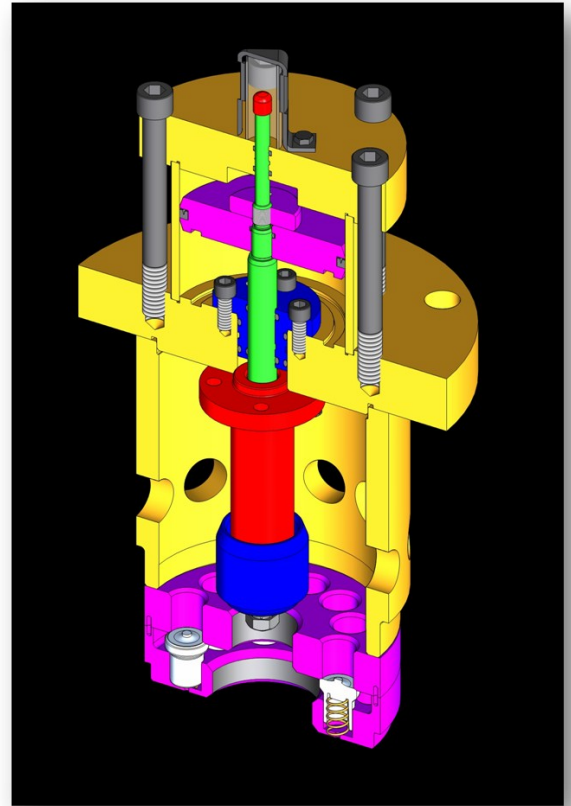

**ACI** Services, Inc.

*Reciprocating Compressor Experts*

125 Steubenville Ave. • Cambridge, Ohio 43725

Phone: (740) 435-0240 • Fax: (740) 435-0260

Visit our websites: [www.ACIServicesInc.com](http://www.ACIServicesInc.com)

[www.CompressorConnection.com](http://www.CompressorConnection.com)