

Product Bulletin PB-0102

Installation and Care of ACI ExactoTorque™ Piston Rod Nuts

1.0 SCOPE

This procedure applies to the installation and removal of ACI Services, Inc. ExactoTorque™ specialty nuts. While the procedure defines the application of these custom engineered devices specifically to reciprocating compressor piston rod nut applications, the general procedure is applicable to all applications of ExactoTorque™ nuts.

2.0 COMPONENTS

The ExactoTorque™ piston rod nut is a precision device that is engineered for each specific application. Each nut assembly consists of four or five basic components (Figure A).

- 2.1 Nut body which threads onto the piston rod.
- 2.2 Jackscrews that individually thread into the nut body.
- 2.3 Bearing pads that are seated between each individual jackscrew and the crosshead boss face or, where applicable, the backing plate (See Figure B).
- 2.4 An o-ring that is assembled onto each pad as a friction device to hold the pads in their counter bore during handling of the nut.
- 2.5 An optional backing plate (see 2.1).

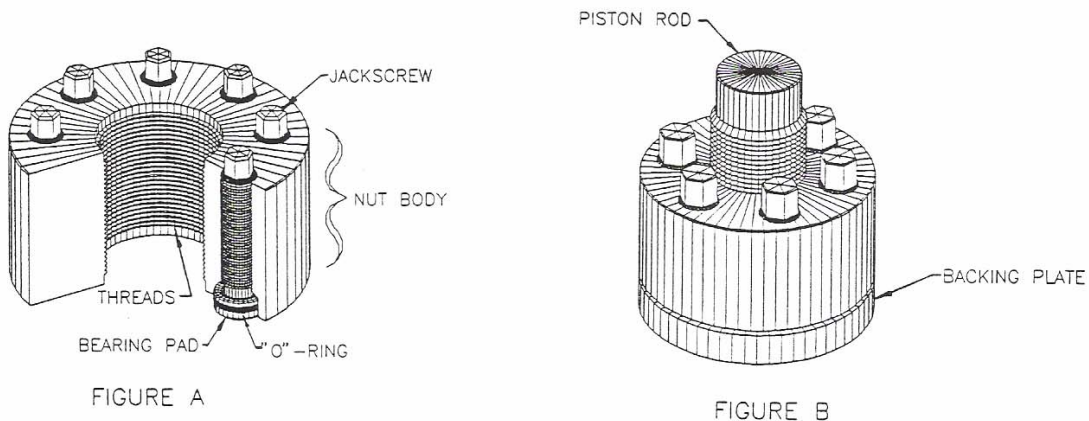

2.1 Backing Plate

A backing plate is required in cases where the crosshead face, or other bearing surface, does not supply a sufficient surface for full bearing pad contact. (Figure B) The ExactoTorque™ nut is the same, with or without the backing plate.

3.0 TORQUE VALUES

The ACI ExactoTorque™ torque values assume that the threads on each jackscrew are clean and free of debris and that the threads and bearing faces are coated with petroleum, such as Lubriplate 130-A or 630-AA or the equivalent. See the specific ExactoTorque™ assembly drawing for the specified jackscrew assembly torque.

Caution! - DO NOT use molybdenum disulfide or Teflon lubricant. The high lubricity will cause excessive fastener loads.

Please reference to the torquing section of this procedure and Figure C.

4.0 INSPECTION OF THE ExactoTorque™

Before installing the nut on the piston rod, remove the bearing pads and ensure that the spherical bearing faces of the jackscrews and the pads are clean and free of debris. Before reinstalling the ExactoTorque™ nut, inspect and replace any jackscrews and bearing pads which display excessive galling or pitting. Grease the spherical face of the bearing pads prior to reassembly in the nut body. Position the bearing pads in the counter bores so that the flat pad faces are flush with the face of the nut body.

5.0 INSTALLATION OF THE ExactoTorque™ NUT TO THE CROSSHEAD AND PISTON ROD

For installation of the ExactoTorque™ nut on compressor piston rods, carefully follow the steps listed below.

- 5.1 Properly lock out and tag out the machine to prevent the accidental rotation of starting of the unit. It is essential that the unit does not roll during this procedure.

- 5.2 Thread the ExactoTorque™ nut onto the piston rod. Remember to allow sufficient room for the nut, backing plate and free length for piston rod engagement in the crosshead. If a backing plate is required, it can now be installed.
- 5.3 With assistance, ease the piston rod forward until the piston rod end is in contact with the crosshead. The piston rod should be slowly screwed in to the crosshead to the proper depth. Refer to the OEM guidelines concerning the proper engagement in the crosshead.

Caution! – Keep hands clear when moving the piston rod to the crosshead.

- 5.4 Once the proper piston rod engagement has been made in the crosshead, the ExactoTorque™ can be threaded down the rod until it is within .040 - .030 in. (1.01 – 0.76 mm) of the crosshead. A feeler gauge can be used to check the necessary clearance.
- 5.5 If a backing plate is used an additional step is needed before setting the ExactoTorque™. Hand tighten (without using a wrench) the jackscrews to set the backing plate against the crosshead. Then loosen the jackscrews and check the clearance as done previously in step 5.4.
- 5.6 Before setting the jackscrews a dial indicator should be set at the top (12:00 o'clock) position. Slowly jack up the piston rod (near the crosshead) and measure the clearance in the piston rod and the crosshead threads. Set the piston rod at half the clearance figure observed.
- 5.7 Hand tighten (without using a wrench) all jackscrews to firmly seat bearing pads against the crosshead or backing plate.
- 5.8 Install two (2) dial indicators to measure the movement in the horizontal and vertical planes.
- 5.9 Follow the torquing sequence and the torque value for the specific ExactoTorque™ application. See the specific ExactoTorque™ assembly drawing for the specified jackscrew assembly torque.
- 5.10 When torquing the jackscrews on the back side of the ExactoTorque™, it may be necessary to use an adapter. The use of adapters is covered in the section on torque wrenches and adapters, such as shown in Figure D.

Caution! – It is important to calculate the correct adjusted torque when using an adapter. Adapters are available from ACI for the various ExactoTorque™ nuts.

- 5.11 The torque values should be increased in 20% steps until the required specified torque is reached. Follow the appropriate torque sequence shown in figure C. In turn, tighten all jackscrews to 20%, then 40%, 60%, 80% and finally 100% of the specified torque, using the sequence.

- 5.12 The dial indicators must be monitored during the torquing process. If at anytime, the deflection on either dial exceeds 0.0005 in. (0.01 mm), the tightening sequence should be changed to “0” the indicated deflection on the dials. When complete, the nut should be torqued at 100% and the dials should read “0”.
- 5.13 After the ExactoTorque™ has been properly torqued, the nuts must be lock wired if the application warrants it. Reference the section on proper lock wire technique.
- 5.14 Record all notes relative to the ExactoTorque™ installation. Include the rod run out and compare it with figures from the last installation of the piston rod on this particular compressor throw.

Warning! – *ExactoTorque™ nuts should never be used to adjust compressor piston rod runs out. Consult the equipment manufacturer concerning rod run out issues.*

Warning! - *Failure to follow the proper torquing sequence can deflect the piston rod and create excessive bending stress that can lead to premature failure of the piston rod.*

6.0 ExactoTorque™ REMOVAL

The ExactoTorque™ nut removal process should follow the installation procedure, but essentially in reverse order. The dial indicators are not required when the nut is removed.

- 6.1 Properly lock out and tag out the machine to prevent the accidental rotation of starting of the unit. It is essential that the unit does not roll during this procedure.
- 6.2 Completely remove the lock wire from all jackscrews and discard it. Lock wire should never be reused.
- 6.3 The nuts should be loosened in about 20% steps until the all jackscrews are loose. Follow the appropriate torque sequence shown in figure C.

Caution! – *The torque sequence must be followed when the nut is removed. Otherwise jackscrews may seize due to excessive loads.*

- 6.4 When loosening the jackscrews on the back side of the ExactoTorque™, it may be necessary to use an adapter. The use of adapters is covered in the section on torque wrenches and adapters, such as shown in Figure D.
- 6.5 When all jackscrews are loose, carefully hand rotate the ExactoTorque™ nut away from the crosshead face and unthread the piston rod from the crosshead.

7.0 ExactoTorque™ TORQUING PROCEDURE

The ACI torque values assume that the threads on each jackscrew are clean and free of debris and that the threads and bearing faces are coated with petroleum, such as Lubriplate 130-A or 630-AA or the equivalent. DO NOT use molybdenum disulfide or Teflon lubricant. The high lubricity will cause excessive fastener loads. See the specific ExactoTorque™ assembly drawing for the nut for the specified jackscrew assembly torque.

Tighten the jackscrews in pairs that are 180 degrees apart, alternating around the bolt circle. (Figure C) until the final torque load is reached. If lock wire is used, lock wire the jackscrews in pairs using the method illustrated in the section entitled

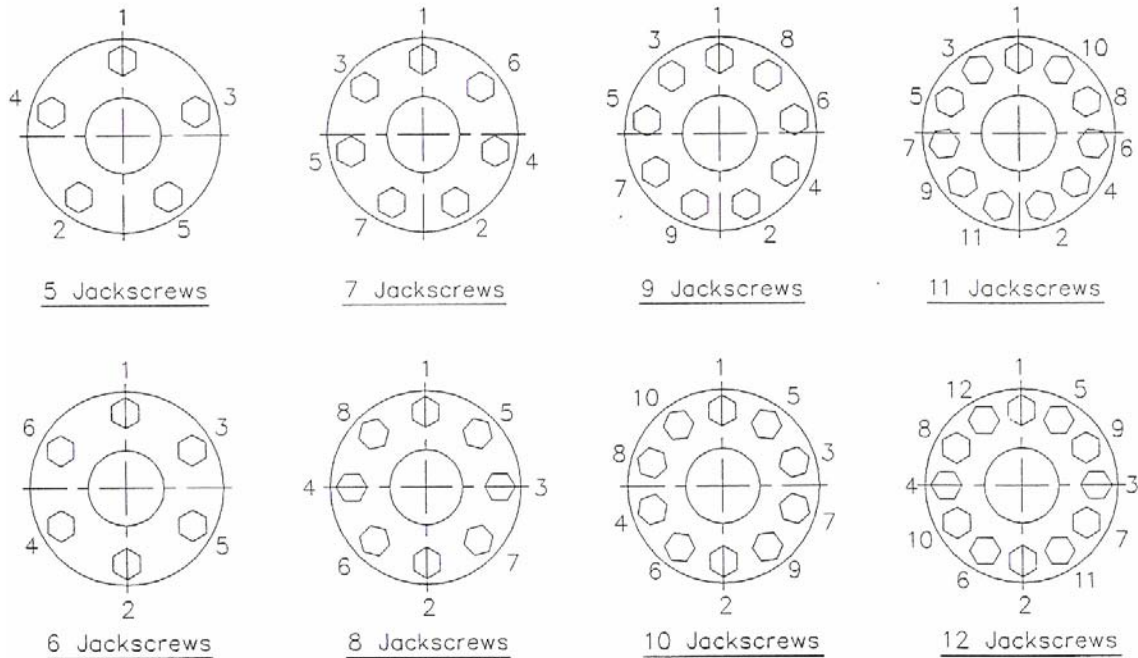

FIGURE C

8.0 TORQUE WRENCHS AND ADAPTERS

It is important, once the pull point has been established on the torque wrench, that the pull be concentrated as much as possible at the point. It is equally important that the effective length of the adapter be measured parallel with the length of the torque wrench. (Figure D).

Caution! - When it is necessary to use torque wrenches with adapters, be sure to consider basic techniques and procedures concerning adapters.

FORMULA $T_1 = T_2 \frac{L_1}{L_1+L_2}$

- T₁ = Torque in Ft. Lbs. to be set or read on torque wrench.
- T₂ = Actual torque in Ft. Lbs. required to be exerted on jackscrews.
- L₁ = Length in inches between drive on torque wrench and pull point.
- L₂ = Effective adapter length in inches.

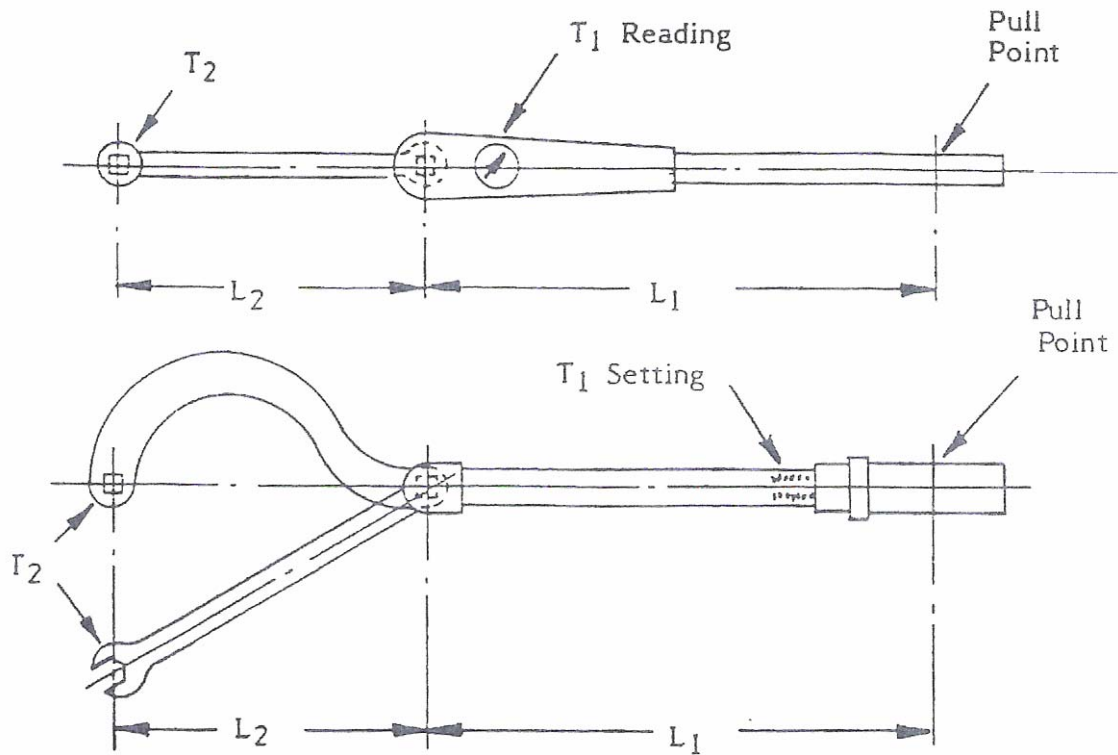

9.0 LOCK WIRE

This type of locking device is used on fasteners so that they remain in place. Properly installed lock wire uses one fastener to keep another secure. Lock wire must be tight and never over-stressed. When lock wire, confirm that the location of wire will not obstruct pathways of other components. Only use wire exclusively designed for lock wire applications. The following lock wire installation procedure should be used.

- 9.1 Always wire fasteners in pairs. If there is an odd number, only one group of three is permitted.

- 9.2 The hole in the jackscrew must be positioned between the 2:00 and 6:00 o'clock positions in relation to a plane passing through the centers of two (2) fasteners (for jackscrews right hand threads).
- 9.3 Insert one end of the wire through the hole; wrap the end around the fastener in a clockwise direction (for right hand threads). See step 1.
- 9.4 Twist the wire in a clockwise direction, keeping tension on the wire. See step 2.
- 9.5 Push one end of the wire through the hole in the second fastener and wrap the other end around the fastener in a counterclockwise direction, then finish twisting both ends of the wire counterclockwise. See step 3.
- 9.6 Trim excess off wire and turn twisted ended inward, alongside the fastener. See step 4.
- 9.7 When using left hand threads, reverse the clockwise and counterclockwise instructions.
- 9.8 If the ExactoTorque™ assembly does use lock wire, ACI recommends the jackscrew torque be checked during routine compressor inspections

Caution! – *Avoid sharp ends on the wire that might cause injury to personnel or scratch finished surfaces.*

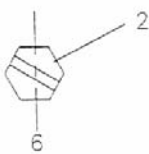
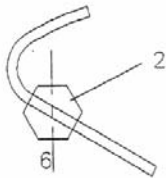

Step 1

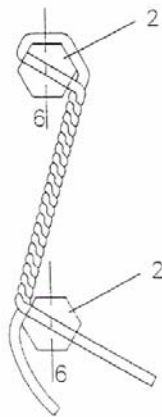

Step 2

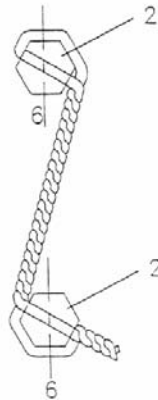

Step 3

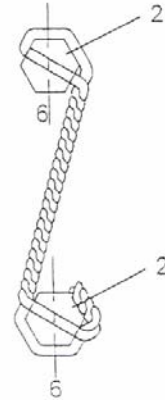

Step 4

Caution! - *The ExactoTorque™ piston rod nut is a precision device that is engineered for each specific application. The nut and its components should not be modified any way without the consultation and written approval of ACI Services Inc.*