

Torque Application to the Spanner Nut Securing the Unloader Actuator Piston to the Unloader Shaft

ACI Services, Inc. PB-0108 Rev. 2; January 31, 2013

This product bulletin is an instruction for applying torque required for assembling the spanner nut (illustration 1) onto the unloader shaft, thus securing the unloader actuator piston (illustration 1).

First, install the unloader actuator piston onto the unloader shaft. Then, install the spanner nut onto the unloader shaft.

CAUTION: Avoid damaging the unloader shaft o-ring sealing surface with the spanner nut shown in illustration 1 or wrench assembly shown in illustration 3.

Next, place the wrench assembly over the shaft so that the dowel pins engage the holes on the spanner nut. Turn spanner nut until it is snug against the unloader actuator piston. Then, place an appropriate torque wrench onto the wrench assembly.

FOR ACTUATORS WITH A BALANCED PLUG DESIGN

Once the wrench assembly is in place, clamp the drake lock nut (illustration 2) secured to the unloader plug (illustration 2) on opposite end of unloader shaft (illustration 2). Then, apply the appropriate amount of torque per table below (refer to the unloader assembly drawings for spanner nut size).

FOR ACTUATORS WITH A SOLID PLUG DESIGN

SHAFT WITH FLATS: Once the wrench assembly is in place, clamp the unloader shaft on the flats on or above the plug area (illustration #5) so that the unloader shaft does not rotate.

SHAFT WITHOUT FLATS: Once the wrench assembly is in place, clamp the unloader shaft above the solid plug area (illustration 4) using protective device so that the unloader shaft with a solid plug (e.g. a locking vise wrench with a rubber protective sleeve) does not have the ability to rotate.

Then, apply the appropriate amount of torque per table below (refer to the unloader assembly drawings for spanner nut size).

CAUTION: Ensure when applying torque to the spanner nut that the drake locking nut or an unloader shaft with a solid plug on the opposite end of the unloader shaft does not turn. If the drake lock nut does turn, it must be properly retorqued.

SPANNER NUT TORQUE:

1/2-20 UNF Spanner Nut (3/4" Diameter Unloader Shaft)	108 IN-LBS
5/8-18 UNF Spanner Nut (1" Diameter Unloader Shaft)	228 IN-LBS

CAUTION: DO NOT OVER TORQUE! Applying too much torque may cause excessive damage to unloader actuator piston or unloader shaft.

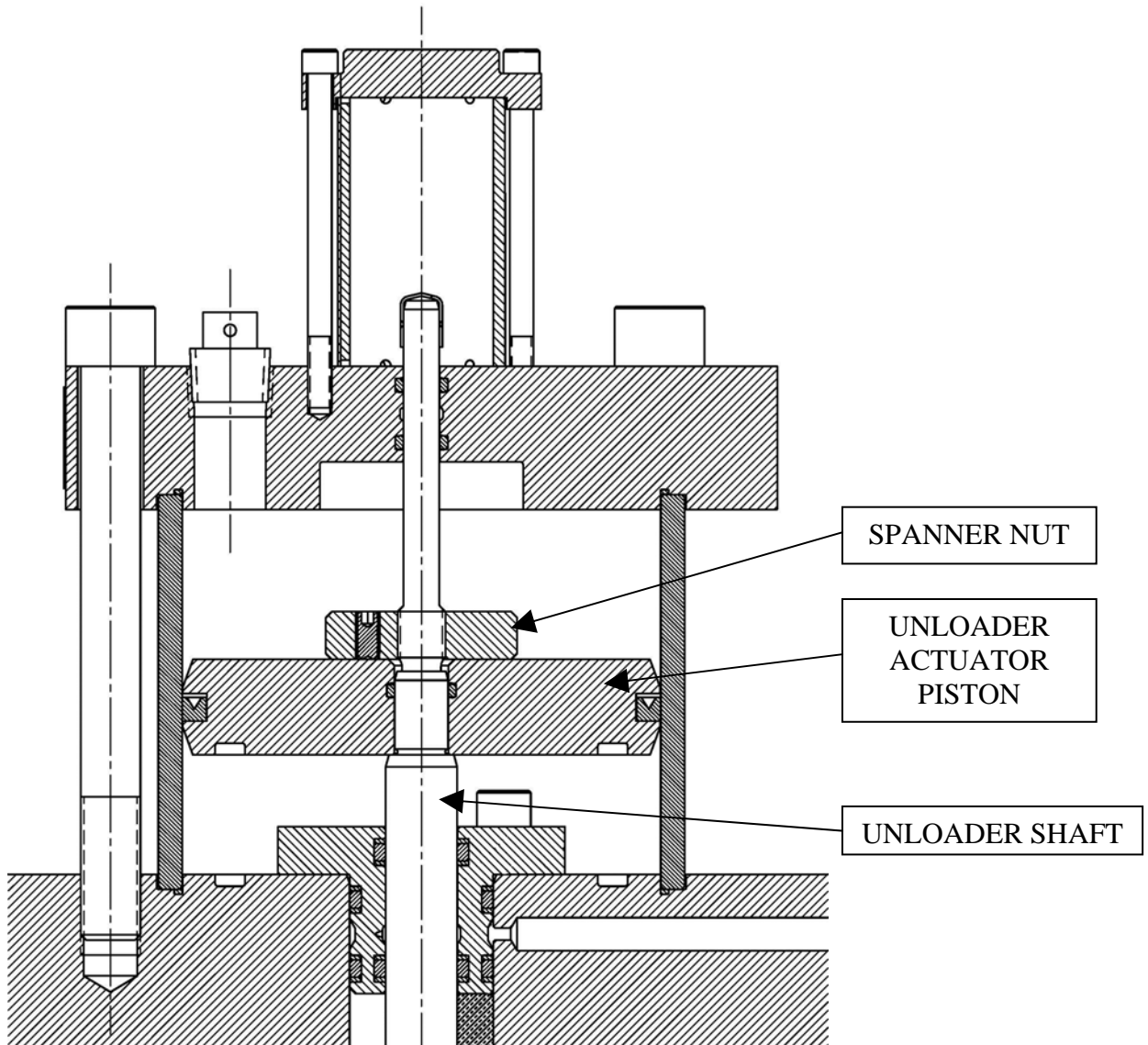
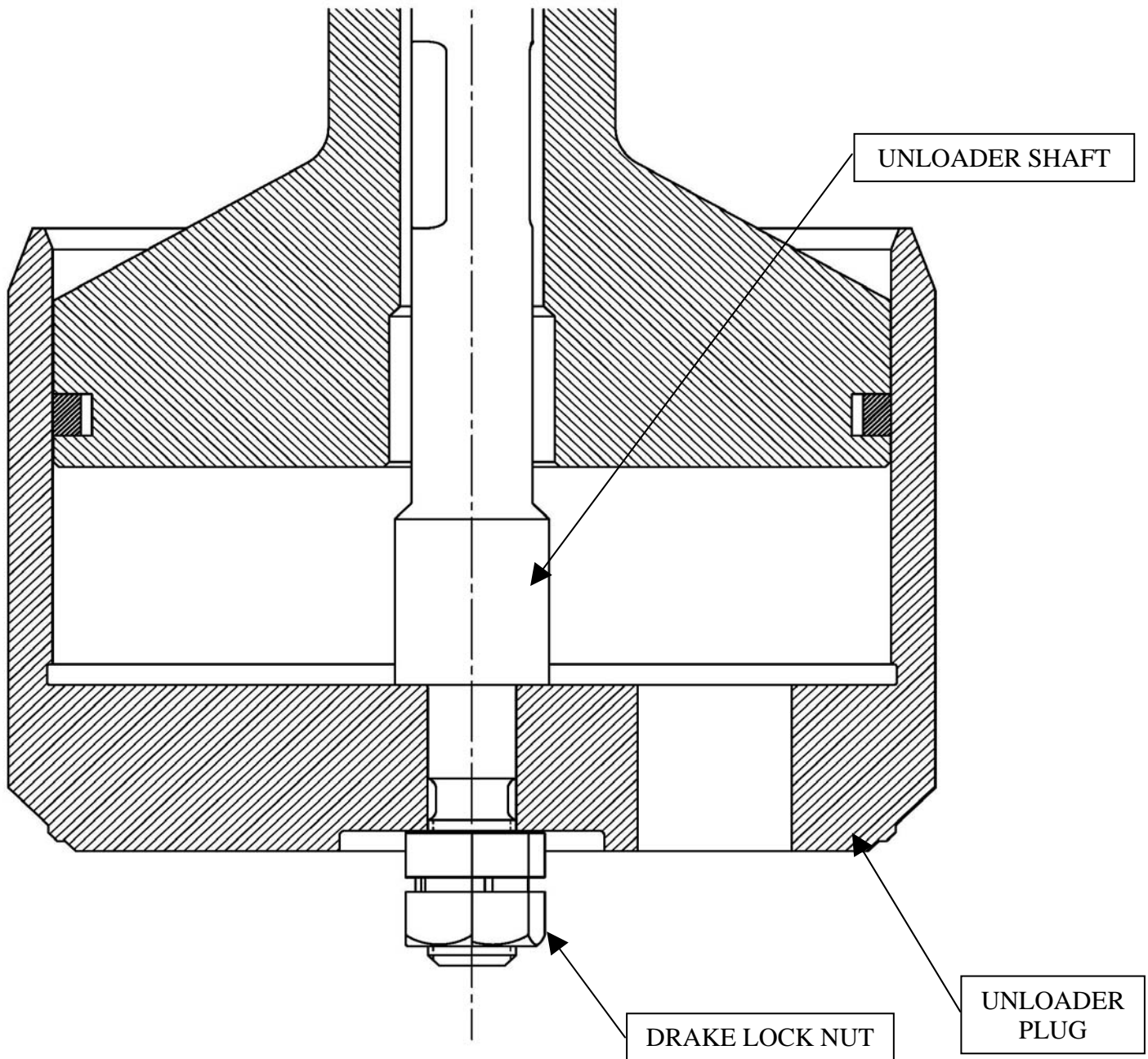
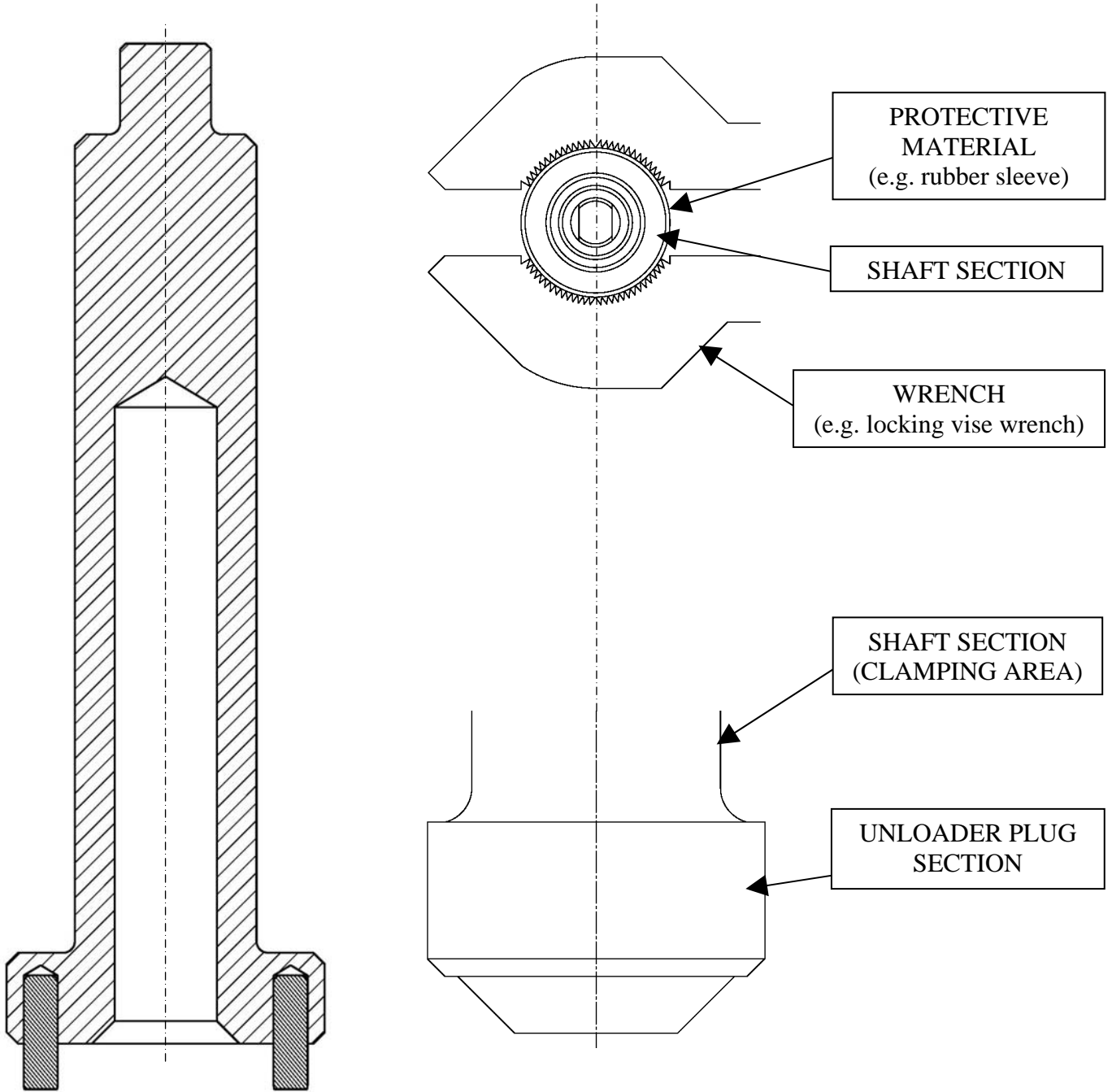

ILLUSTRATION 1:
ACTUATOR TOP HALF

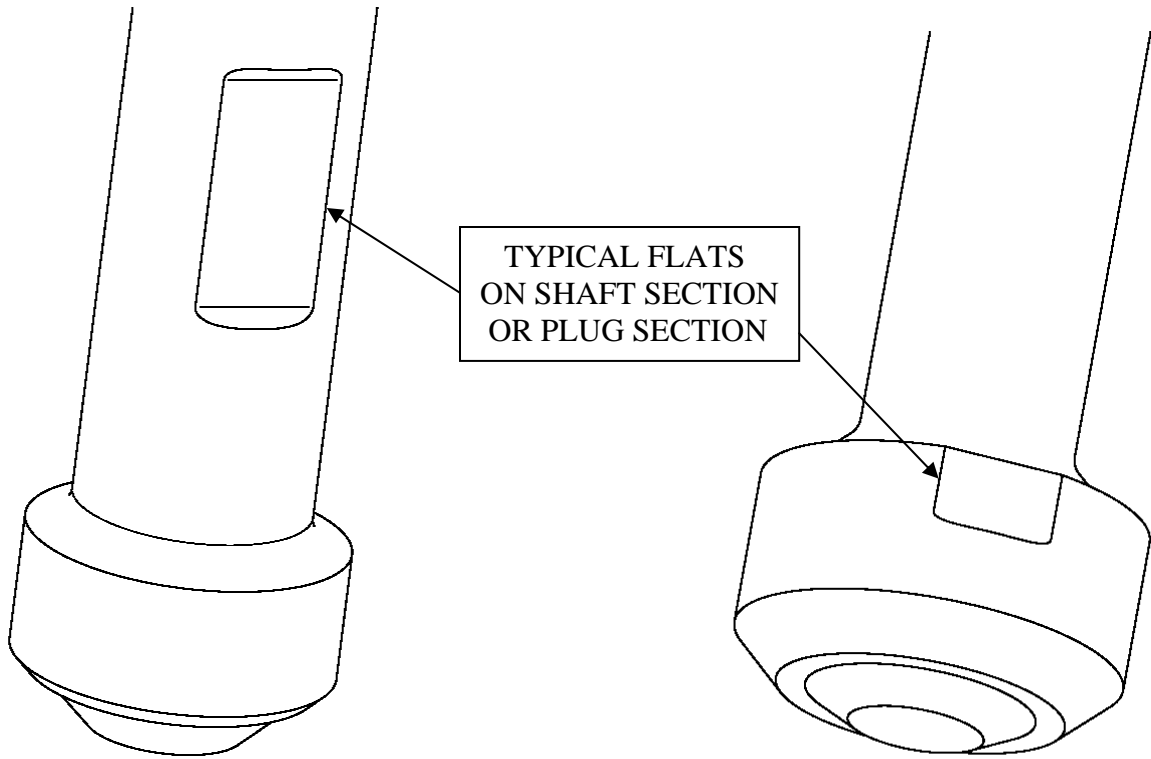

**ILLUSTRATION 2:
ACTUATOR BOTTOM HALF (with Balanced Plug)**



**ILLUSTRATION 3:
WRENCH ASSEMBLY
T04012#1 (SOLD SEPARATELY)**

**ILLUSTRATION 4:
ACTUATOR BOTTOM HALF
(with Solid Plug without Flats)**



**ILLUSTRATION 5:
ACTUATOR BOTTOM HALF
(with Solid Plug with Flats)**